



# 目 录

.....	1
.....	1
.....	2
J1-1	2
T1-1	4
T1-2	6
T1-3	8
T1-4	10
T1-5	12
T1-6	14
T1-7	16
T1-8	18
T1-9	20
T1-10	22
T1-11	24
T1-12	26
T1-13	28
T1-14	30
T1-15	32
.....	34
J1-2	34
T2-1	36
T2-2	38
T2-3	40
T2-4	42
T2-5	44
T2-6	46
T2-7	48
T2-8	50
T2-9	52
T2-10	54
T2-11	56
T2-12	58
T2-13	60
T2-14	62
T2-15	64
.....	66
H1-1 STM32	66

T3-1	.....	68
T3-2	.....	70
T3-4	.....	73
T3-5	.....	75
T3-6	.....	77
T3-8	.....	80
T3-9	.....	82
T3-10	.....	84
	.....	85
H1-2 Android studio	.....	85
T4-1	.....	87
T4-2	.....	88
T4-3	.....	89
T4-4	.....	90
T4-5	.....	91
T4-6	.....	92
T4-7	.....	93
T4-8	.....	94
T4-9	.....	95
T4-10	.....	96

		J1-1	15 T1-1 T1-15
		J2-1	15 T2-1 T2-15
		H1-1STM32	10 T3-1 T3-10
		H2-1 AndroidStudio	10 T4-1 T4-10



J1-1

(50 )	5		
	5		
	10		
	5		
	15		

		5		0
		5	6S	
50		20	1 IPC-A-610	
		20		
		10		

**T1-1**



# T1-2

## FM

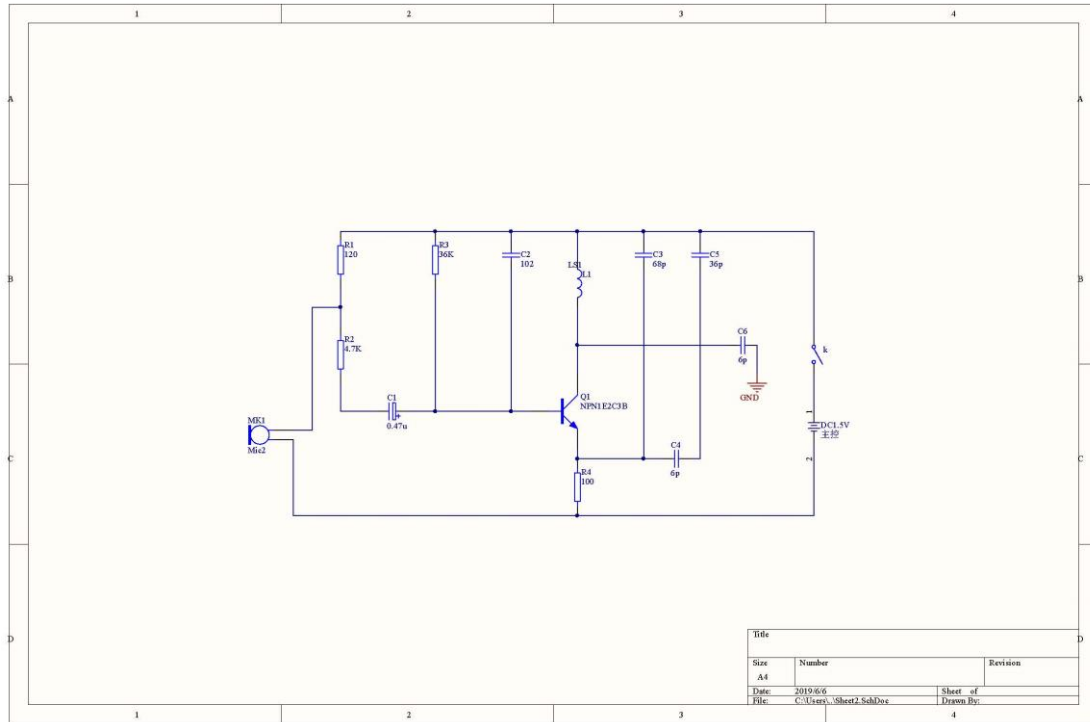

Comment	Description	Designator	Footprint	LibRef	Quantity
0.47u		C1	RB1	CAP3	1
102		C2	RAD0.1	CAP1	1
68p		C3	RAD0.1	CAP1	1
6p		C4, C6	RAD0.1	CAP1	2
36p		C5	RAD0.1	CAP1	1
		DC1.5V	Battery_20	Battery_20	1
	Single-Pole, Single-Th	k	SPST-2	SW-SPST	1
LS1		L1		LS1	1
Mic2	Microphone	MK1	PIN2	Mic2	1
NPN1E2C3B		Q1	TO92A	NPN1E2C3B	1
120		R1	AXIAL0.3	RES	1
4.7K		R2	AXIAL0.3	RES	1
36K		R3	AXIAL0.3	RES	1
100		R4	AXIAL0.3	RES	1



**T1-3**

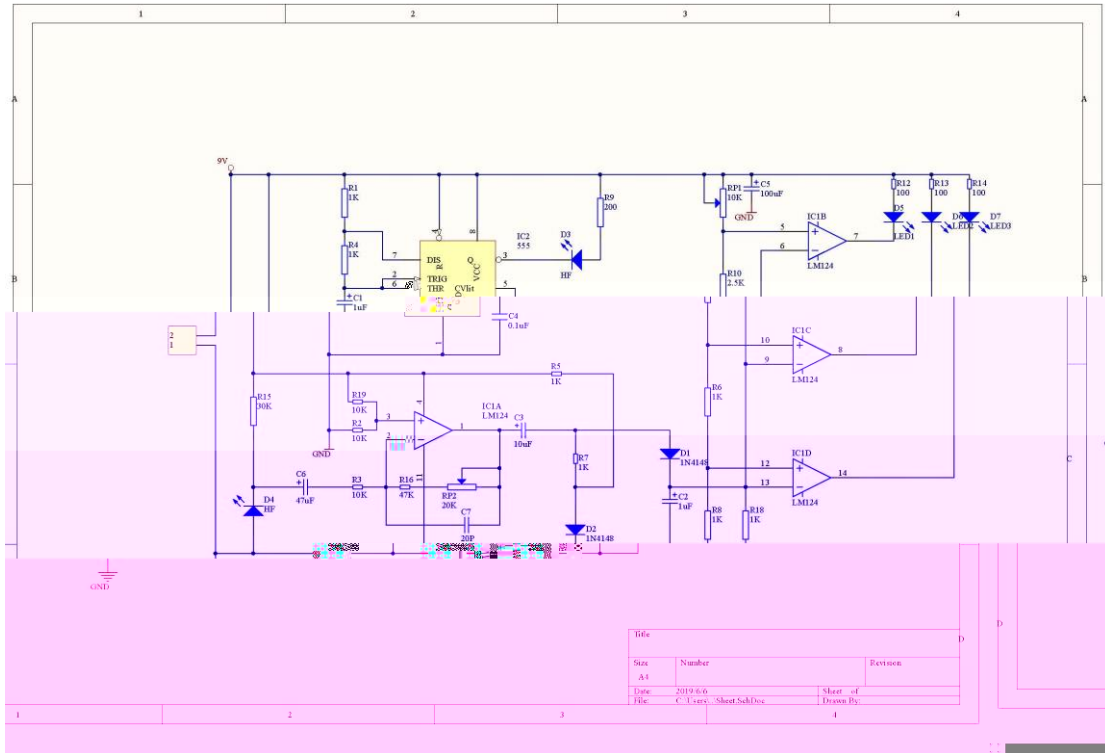

# T1-4



Title		
Scale	Number	Revision
Date	2019.6.6	Sheet of
File	C:\Users\Sheet\Documents	Drawn By

Comment	Description	Designator	Footprint	LibRef	Quantity
1uF	Polarized Capacitor	C1, C2	POLAR0.8	Cap Pol2	2
10uF	Polarized Capacitor	C3	POLAR0.8	Cap Pol2	1
0.1uF		C4	C0.254	C0.254	1
100uF	Polarized Capacitor	C5	POLAR0.8	Cap Pol2	1
47uF	Polarized Capacitor	C6	POLAR0.8	Cap Pol2	1
20P	Capacitor	C7	RAD-0.3	Cap	1
1N4148	High Conductance Fa	D1, D2	DO-35	Diode 1N4148	2
HF	Typical RED GaAs LED	D3, D4	LED-1	LED1	2
LED1	Typical RED GaAs LED	D5	LED-1	LED1	1
LED2	Typical RED GaAs LED	D6	LED-1	LED1	1
LED3	Typical RED GaAs LED	D7	LED-1	LED1	1
LM124		IC1	DIP-14	LM124	1
555		IC2	DIP-8N	Component_1	1
CON2	Header, 2-Pin	J1	HDR1X2	Header 2	1
1K		R1, R4, R6, R8, R18	AXIAL0.3	RES	5
10K		R2, R3, R19	7.6mm	7.6mm	3
1K		R5, R7	7.6mm	7.6mm	2
200		R9	AXIAL0.3	RES	1
2.5K		R10	AXIAL0.3	RES	1
100		R12, R13, R14	7.6mm	7.6mm	3
30K		R15	AXIAL0.3	RES	1
47K		R16	7.6mm	7.6mm	1
10K	Potentiometer	RP1	RVR-1	RPOT2	1
20K	Potentiometer	RP2	RVR-1	RPOT2	1

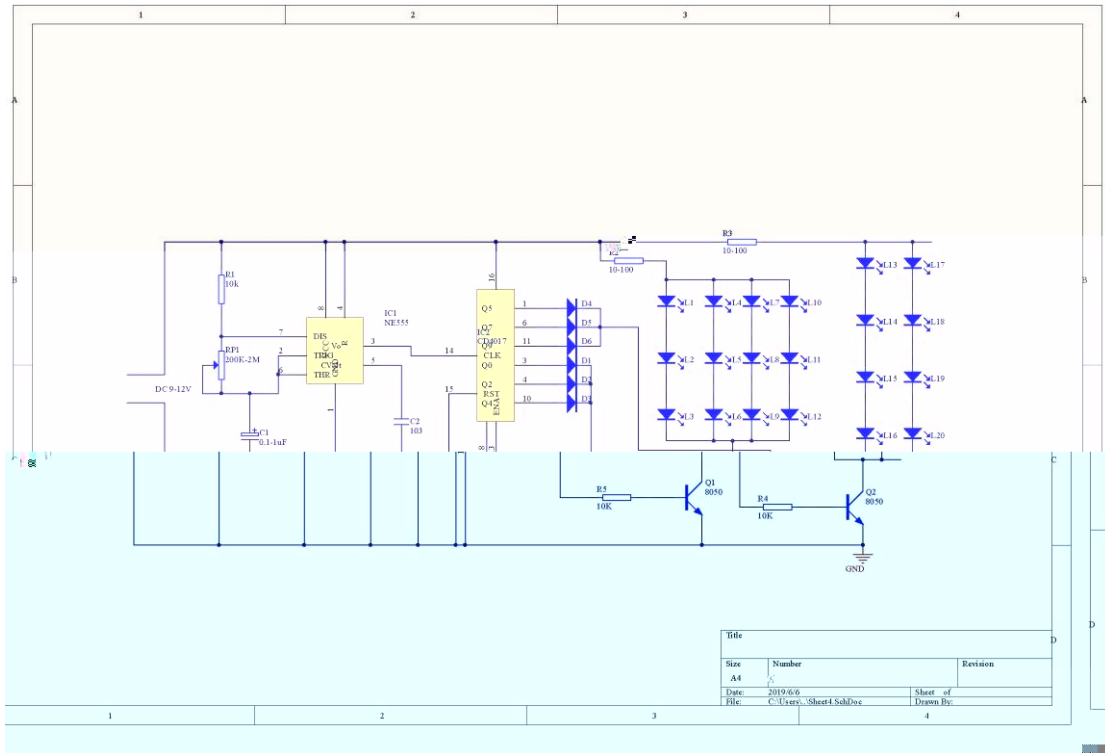
# T1-5



Comment	Description	Designator	Footprint	LibRef	Quantity
0.1-1uF		C1	RB1	CAP3	1
103	SMD-CAP	C2	0603C	CAP-0.1UF	1
0805D		D1, D2, D3, D4, D5, D6	0805D	0805D	6
NE555		IC1	DIP-8N	Component_1	1
CD4017		IC2	DIP-16N	CD4017	1
LED0805		L1, L2, L3, L4, L5, L6, L7, L8, L9, L10, L11, L12, L13, L14, L15, L16, L17, L18, L19, L20	LED0805	LED0805	20
8050	?	Q1, Q2	TO92A	NPN1E2C3B	2
10k		R1, R4, R5	AXIAL0.3	RES	3
10-100		R2, R3	AXIAL0.3	RES	2
200K-2M	Potentiometer	RP1	RVR-1	RPOT2	1





# T1-6

## CD4060

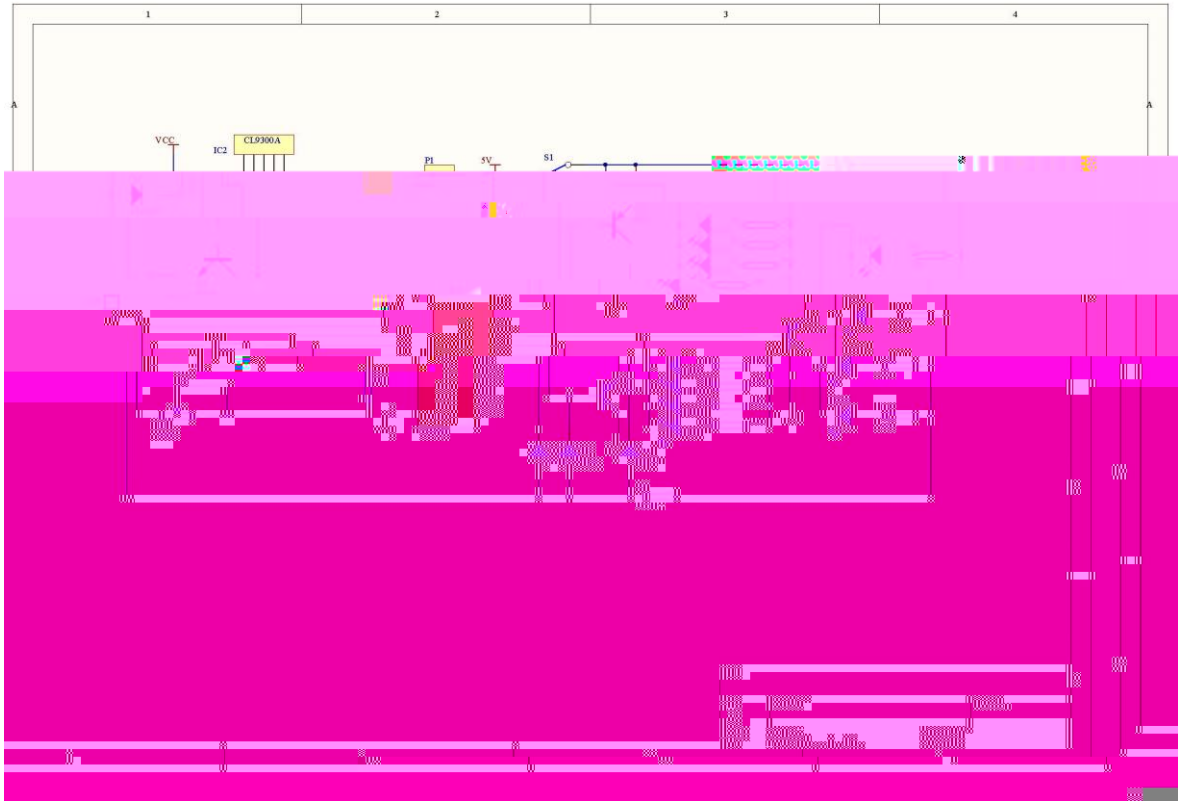

2

Comment	Description	Designator	Footprint	LibRef	Quantity
1uf	Polarized Capacitor	C1	POLAR0.8	Cap Pol2	1
1N4007	1 Amp General Purpose Diode	D1	DO-41	Diode 1N4007	1
1N4148	High Conductance Fast Recovery Diode	D2, D3, D4	DO-35	Diode 1N4148	3
CD4060	16-Bit Binary Counter	IC1	DIP-16N	CD4060	1
CL9300A	LED Driver IC	IC2	HDR1X5	CL9300A	1
LED1	Typical RED GaAs LED	LED1, LED2, LED3, LED4	LED-1	LED1	12
Speaker	Loudspeaker	LS1	PIN2	Speaker	1
Header 2	Header, 2-Pin	P1	HDR1X2	Header 2	1
8050	NPN Transistor	Q1	TO92A	NPN1E2C3B	1
9012	PNP Transistor	Q2, Q3, Q4	TO92A	PNP1E2C3B	3
1.0M	Resistor	R1	AXIAL0.3	RES	1
10K	Resistor	R2	AXIAL0.3	RES	1
220K	Resistor	R4	AXIAL0.3	RES	1
200	Resistor	R5, R6, R7, R8, R9, R10, R11, R12, R13, R14, R15, R16, R17, R18, R19, R20, R21, R22, R23, R24, R25, R26, R27, R28, R29, R30, R31, R32, R33, R34, R35, R36, R37, R38, R39, R40, R41, R42, R43, R44, R45, R46, R47, R48, R49, R50, R51, R52, R53, R54, R55, R56, R57, R58, R59, R60, R61, R62, R63, R64, R65, R66, R67, R68, R69, R70, R71, R72, R73, R74, R75, R76, R77, R78, R79, R80, R81, R82, R83, R84, R85, R86, R87, R88, R89, R90, R91, R92, R93, R94, R95, R96, R97, R98, R99, R100	AXIAL0.3	RES	12
200K	Potentiometer	RP1	RVR-1	RPOT2	1
SW DPDT	Double Pole Double Throw Switch	S1		SW DPDT	1

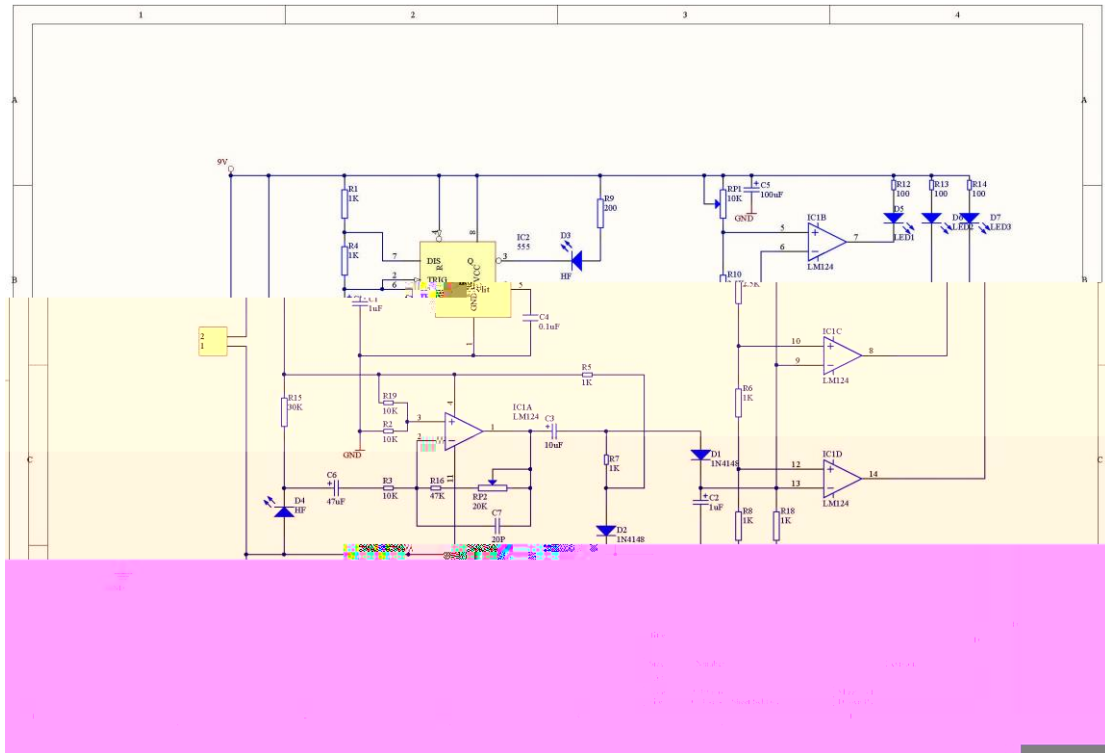

# T1-7



Comment	Description	Designator	Footprint	LibRef	Quantity
		B1	Battery_20	Battery_20	1
103		C1, C2	CAP0.5	CAP0.5	2
100u		C3	RB5/2	RB5/2	1
LED0	Typical INFRARED Ga	D1	LED-0	LED0	1
12K		R1, R7	AXIAL0.3	RES	2
100K		R2, R3, R8	AXIAL0.3	RES	3
1K		R4	AXIAL0.3	RES	1
82K		R5	AXIAL0.3	RES	1
30K		R6	AXIAL0.3	RES	1
50K	Potentiometer	RP1	RVR-1	RPOT2	1
50K		RT	AXIAL0.4		1
Ua741		U1	DIP-8	741	1
Ne555		U2		Component_1	1
Speaker	Loudspeaker	Y	PIN2	Speaker	1

--	--	--	--

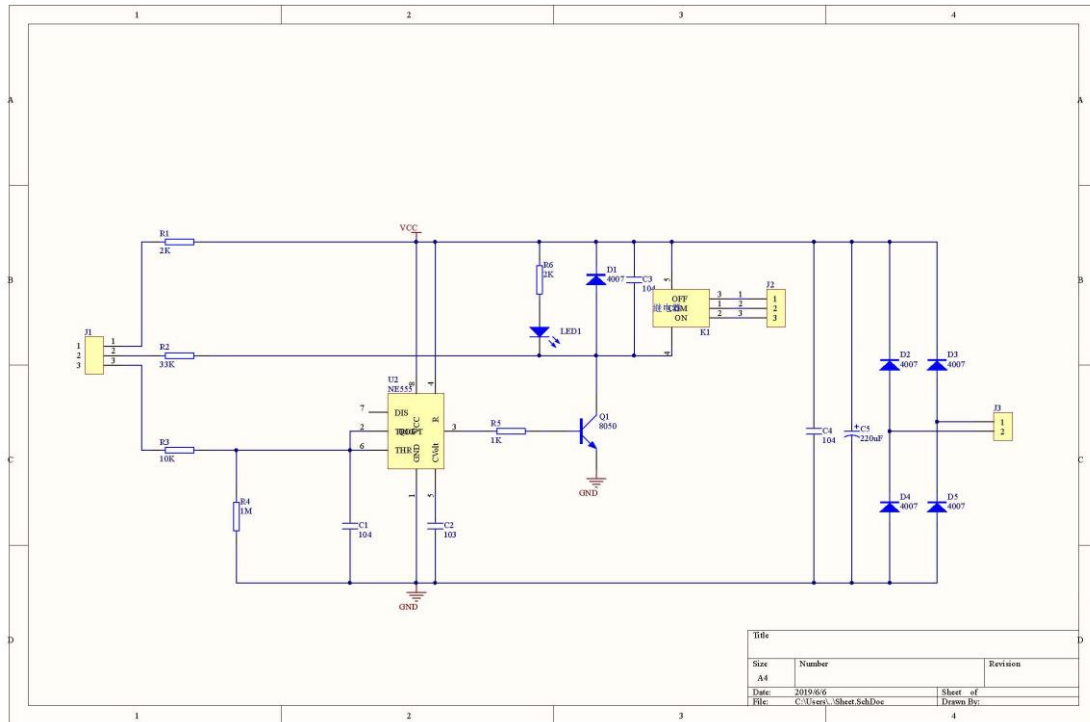

# T1-8



Comment	Description	Designator	Footprint	LibRef	Quantity
104		C1, C3, C4	C0.254	C0.254	3
103		C2	C0.254	C0.254	1
220uF	Polarized Capacitor (H	C5	RB7.6-15	Cap Pol1	1
4007		D1, D2, D3, D4, D5	DO-41-2	DO-41	5
SIP3		J1, J2	SIP3.0-0.254	SIP3.0-0.254	2
SIP2		J3	SIP2-0.254	SIP2-0.254	1
K1		K1		K1	1
LED1	Typical RED GaAs LED	LED1	LED-1	LED1	1
8050		Q1	TO92A	NPN1E2C3B	1
2K		R1, R6	AXIAL0.3	RES	2
33K		R2	AXIAL0.3	RES	1
10K		R3	AXIAL0.3	RES	1
1M		R4	AXIAL0.3	RES	1
1K		R5	AXIAL0.3	RES	1
NE555		U2		NE555	1

**T1-9**

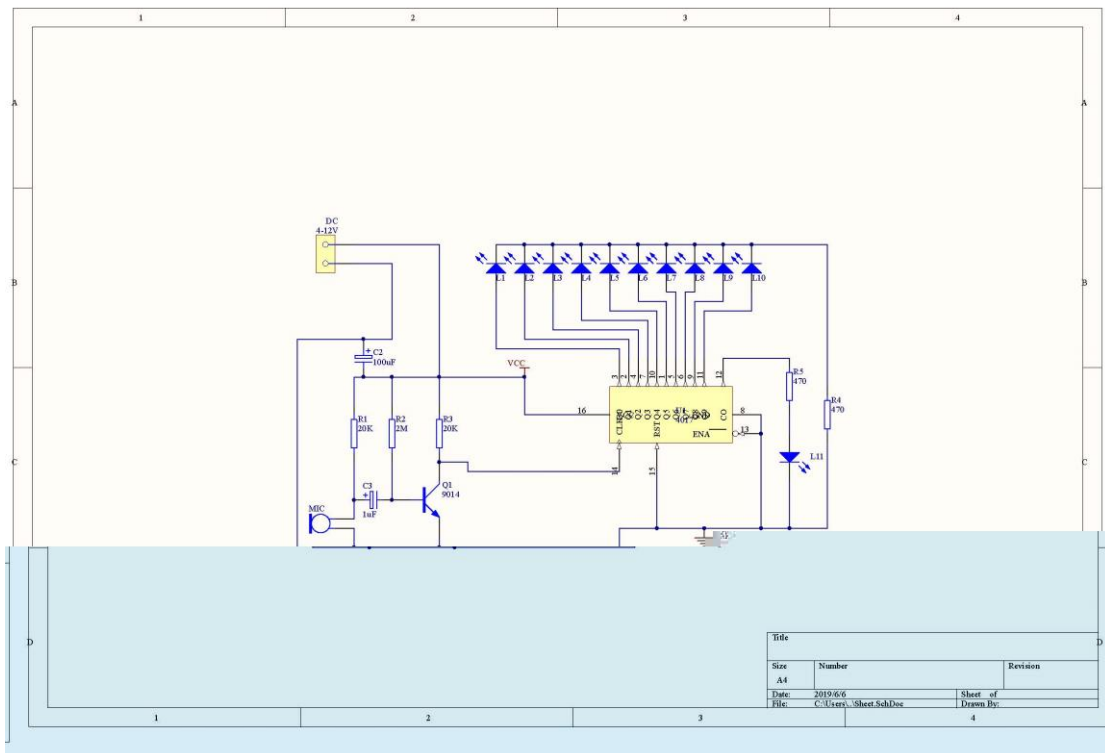
**LED**



Comment	Description	Designator	Footprint	LibRef	Quantity
100uF		C2	RB5/2	RB5/2	1
1uF		C3	RB5/2	RB5/2	1
4-12V		DC	HDR1X2	DC	1
LED1	Typical RED GaAs LED	L1, L2, L3, L4, L5, L6, L	LED-1	LED1	11
Mic2	Microphone	MIC	PIN2	Mic2	1
9014		Q1	TO92A	NPN1E2C3B	1
20K		R1, R3	AXIAL0.3	RES	2
2M		R2	AXIAL0.3	RES	1
470		R4, R5	AXIAL0.3	RES	2
4017		U1	DIP-16	4017	1

--	--	--	--





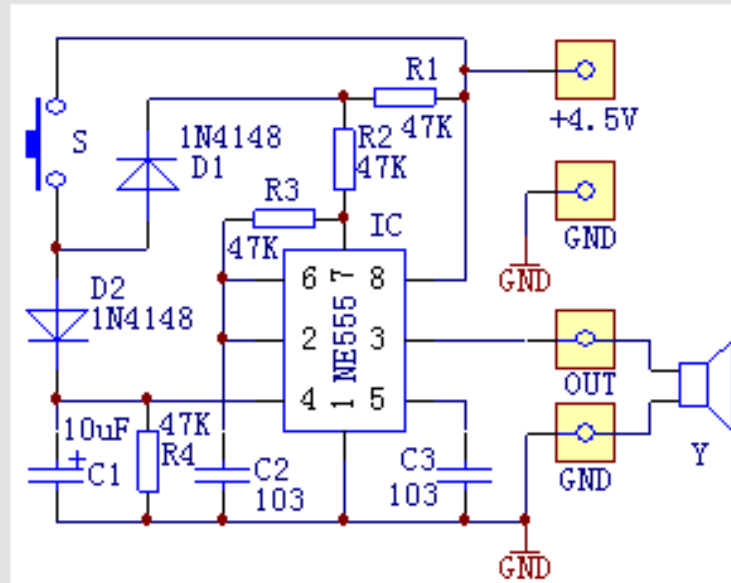

T1-11

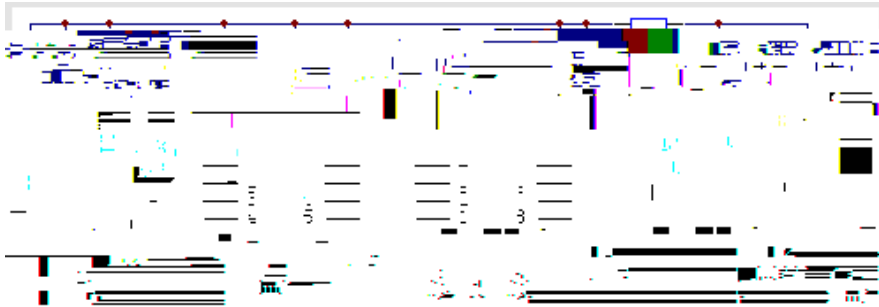

安装顺序	位号	名称	规格	数量
1	R1、R2、R3、R4	电阻	47K	4
	D1、D2	二极管	1N4148	2
2	S	轻触按键	6*6*5mm	1
	IC	集成电路	NE555	1
3	C2、C3	瓷片电容	103	2
4		细导线	6CM	5
5	C1	电解电容	10uF	1
6	Y	喇叭	29MM	1
7	S2	拨动开关	SS12F15	1
8	外壳附件	7号电池弹簧	4件套	1
		螺丝	PA2. 3X5	3
		螺丝	PA2. 3X8	1
		螺丝	PA2. 3X10	1
	外壳	按钮帽		1
		前壳		1
		后壳		1
		电池盖		1
	PCB板	29X37MM	1	

T1-12



安装顺序	位号	名称	规格	数量
1	R1	电阻	470	1
	R2、R3、R4	电阻	1K	3
	R5、R6	电阻	47K	2
	R7	电阻	4.7 欧	1
	D2	二极管	1N4148	1
2	IC1	集成电路	LM393	1
	IC2	集成电路	NE555	1
	集成电路最后安装	集成电路插座	8P	2
3	RP1	可调电阻	B20K	1
	RP2	可调电阻	B500K	1
4	LED2	发光二极管	3mm 红发红	1
5	X1、X2	接线座	2P	2
6	C1、C2	电解电容	100uF/16V	2
	C3	电解电容	10uF	1
	C4	瓷片电容	103	1
7	Q	三极管	9013	1
8	D1	红外接收二极管	黑色	1
9	LED1	红外发射二极管	透明	1
10	K	继电器	5V	1
		PCB 板	35X80mm	1

--	--	--	--

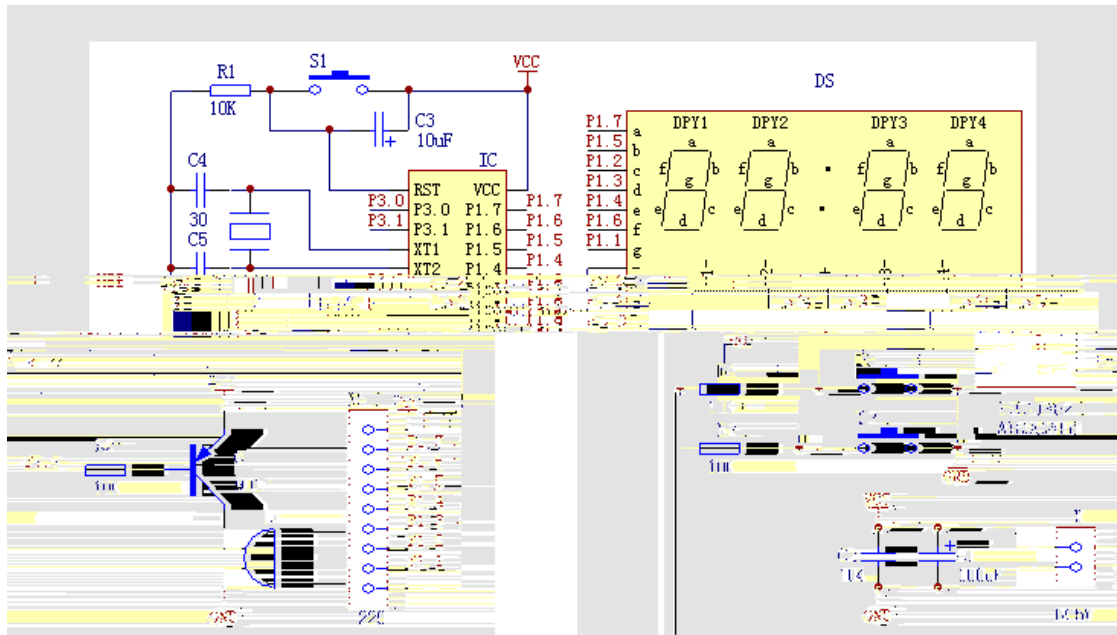
安装顺序	位号	名称	规格	数量
1	R1、R2、R3、R4	电阻	10K	4
2	Y	晶振	3.579M	1
3	C4、C5	瓷片电容	30P	2
4	R5	电阻排	A9-221	1
5	IC (单片机最后安装)	单片机	STC11F02	1
		IC座	20P	1
6	S1、S2、S3	轻触按键	6*6*5mm	3
7	C1	电解电容	100uF	1
	C2	瓷片电容	104	1
	C3	电解电容	10uF	1
	Q	三极管	9012	1
8	LS	无源蜂鸣器	12*8.5mm	1
9	DS	时钟数码管	0.56寸红色共阳	1
10	X	接线座	2P	1
		PCB板	55*60mm	1





安装顺序	位号	名称	规格	数量
1	R1-R6	电阻	2.2K	6
	R7	电阻	820K	1
	D1-D5	二极管	1N4007	5
2	IC1	集成电路插座	18P	1
	集成电路最后安装	集成电路	2272-M4/L4/T4	1
3	LED1、LED2	发光二极管	3mm 红发红	2
4	C3、C4	瓷片电容	104	2
5	C1、C2	电解电容	100uF	2
6	Q1、Q2、Q3、Q4	三极管	9013	4
	IC1	稳压集成电路	78L05	1
7	X1、X2、X3、X4	接线座	3P	4
8	X5	接线座	2P	1

1	10	IC3	无线接收模块	315MHz
1		TX	天线	螺旋导线
1			四键遥控器	315MHz
1			外壳	98X80X28mm
4			螺丝	圆头 PA3X6
1			PCB 板	85X71mm

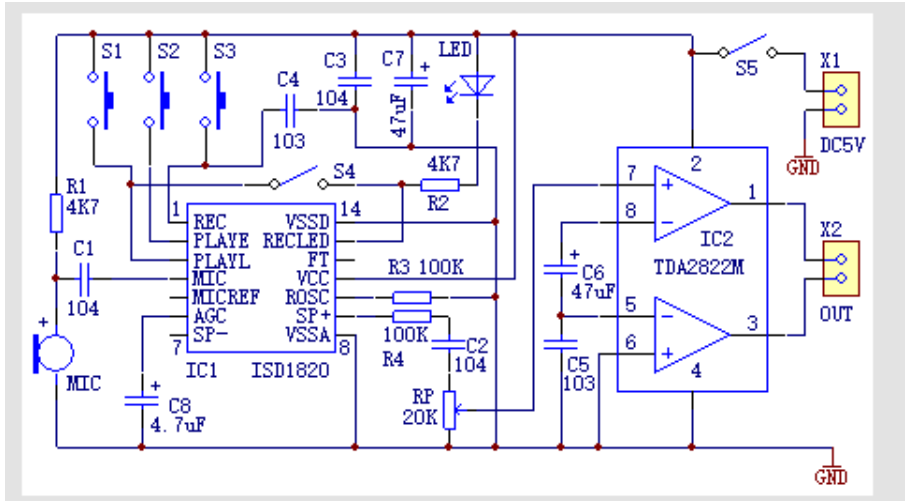
安装顺序	位号	名称	规格	数量
1	R1、R2	电阻	4K7	2
	R3、R4		100K	2
2	IC1	IC座	14P	1
	集成电路最后安装	集成电路	ISD1820	1
	IC2	IC座	8P	1
3	集成电路最后安装	集成电路	TDA2822M	1
	LED	发光二极管	3mm 红发红	1
4	C1、C2、C3	瓷片电容	104	3
	C4、C5		103	2
5	S4	拨动开关	SS12D00	1
6	MIC	驻极体话筒	9*7mm	1
7	RP	可调电阻	B20K	1
	C6、C7		47.7/16V	2

元器件清单表

--	--	--	--

**J1-2**

**T2-1**

1





T2-2

1

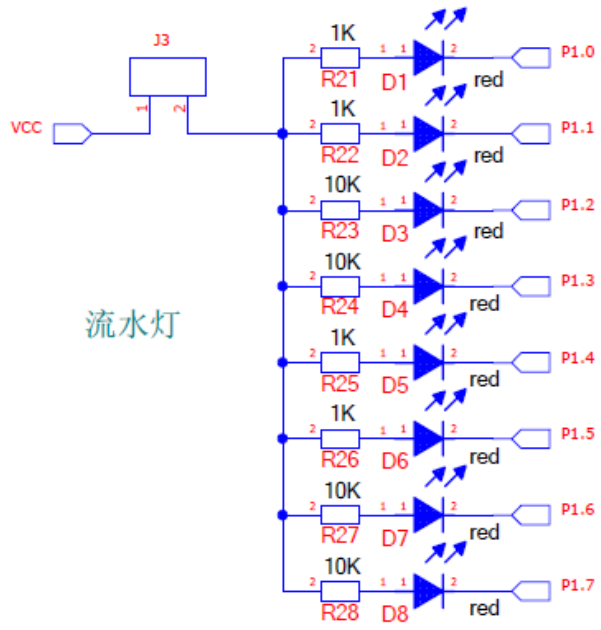

2



T2-3

1

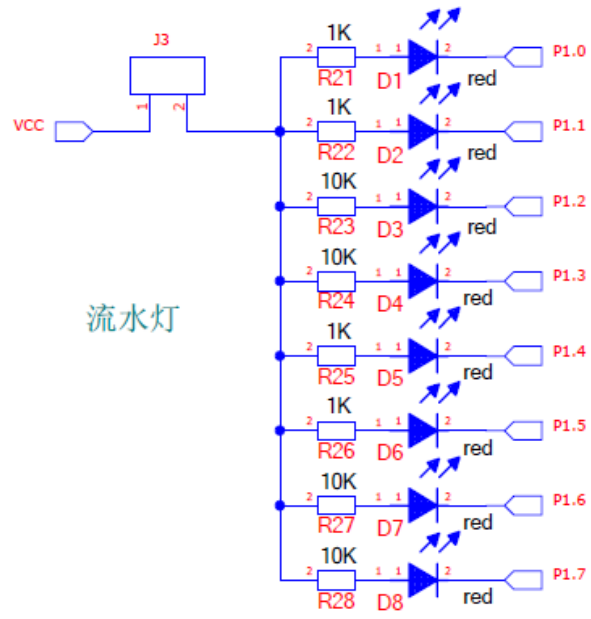

2



T2-4

1

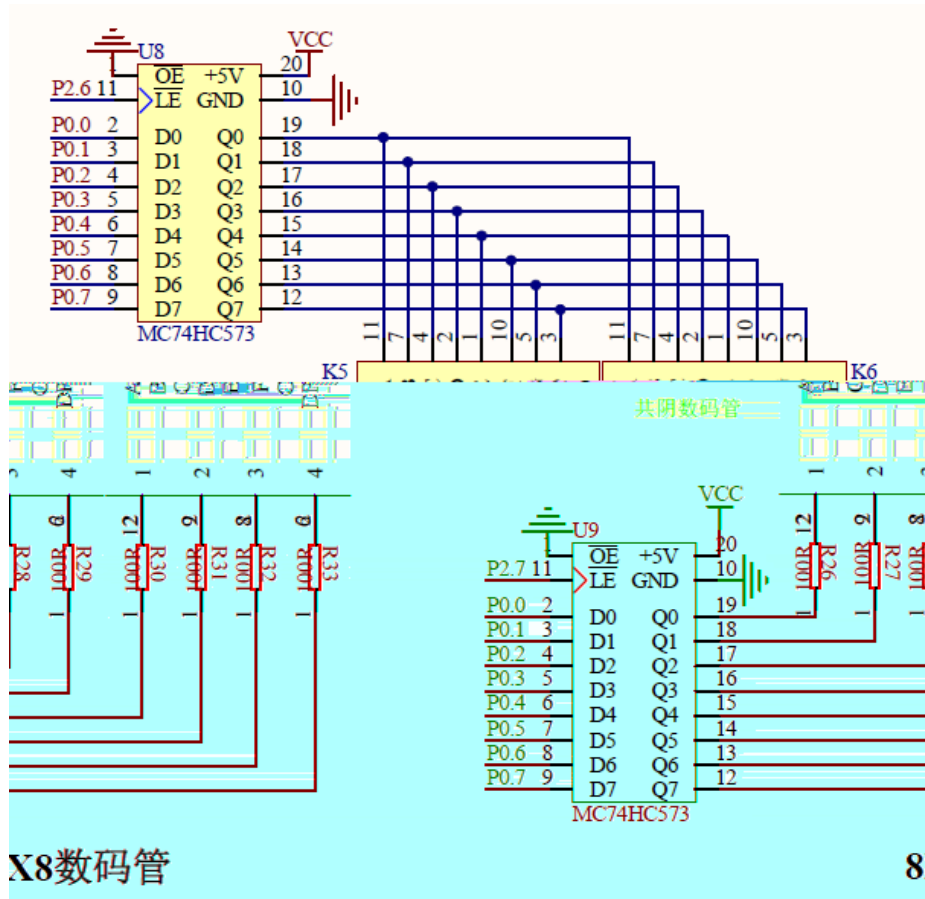



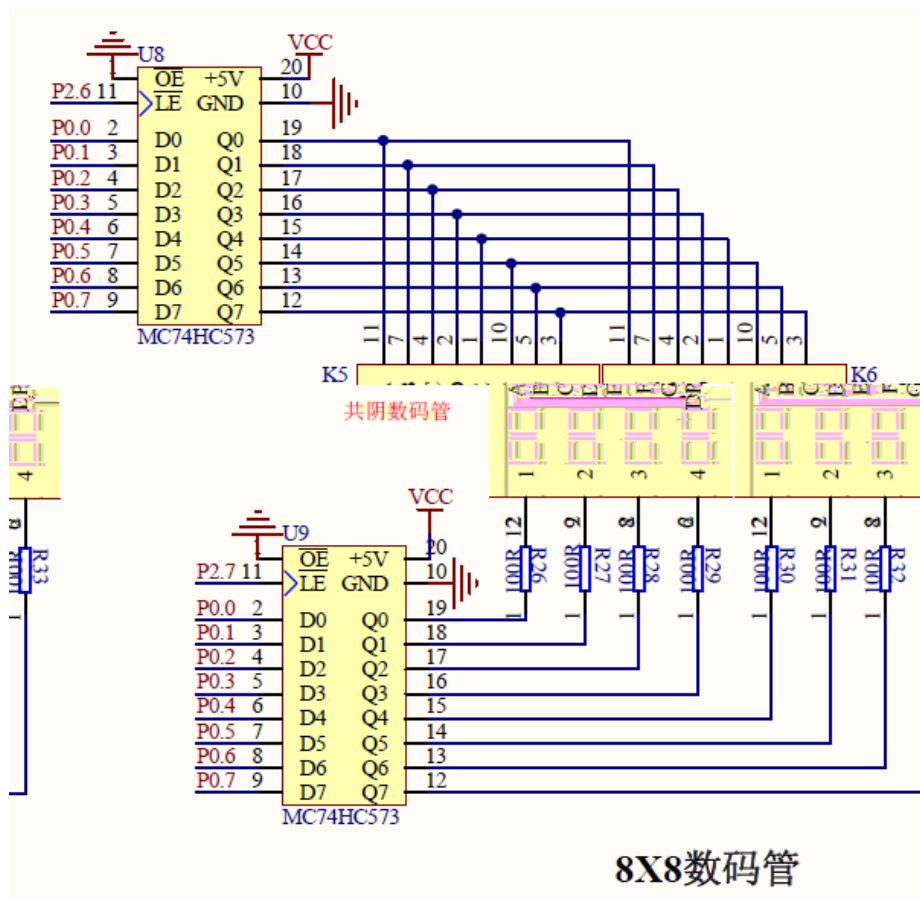





T2-6

1

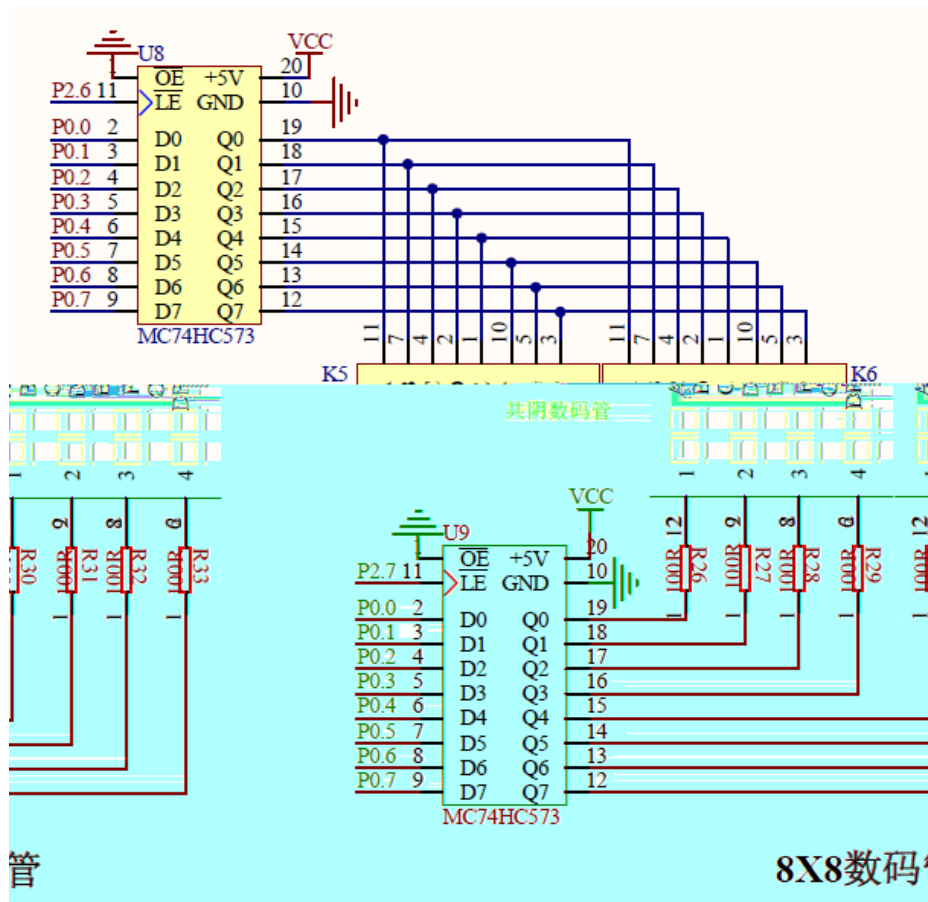



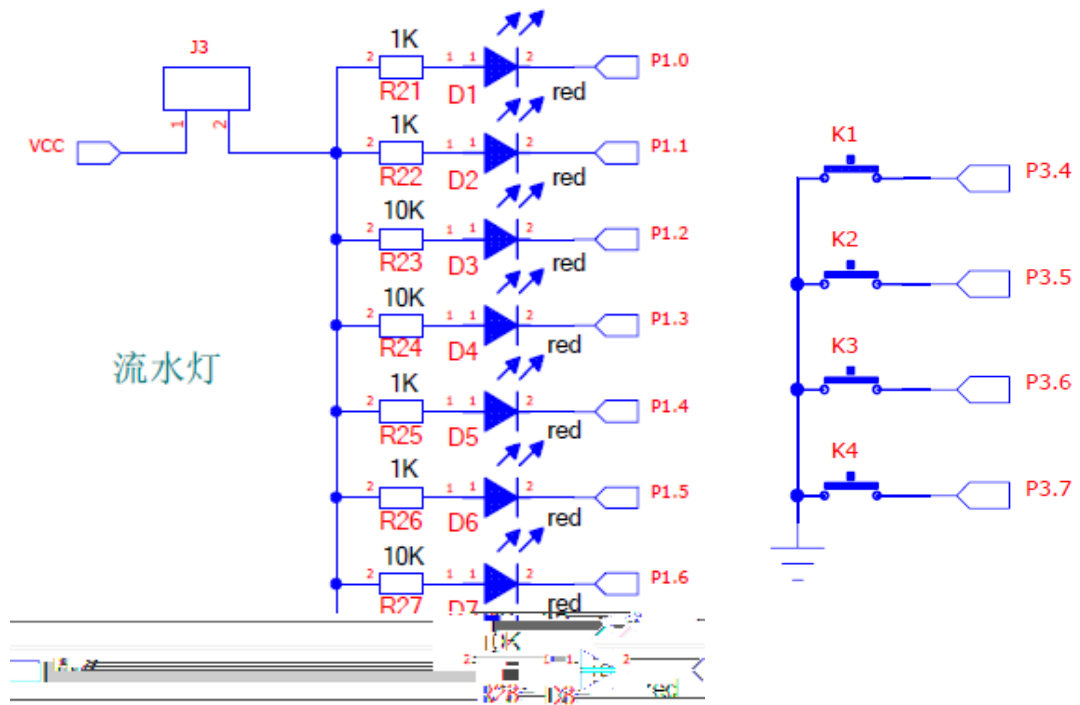



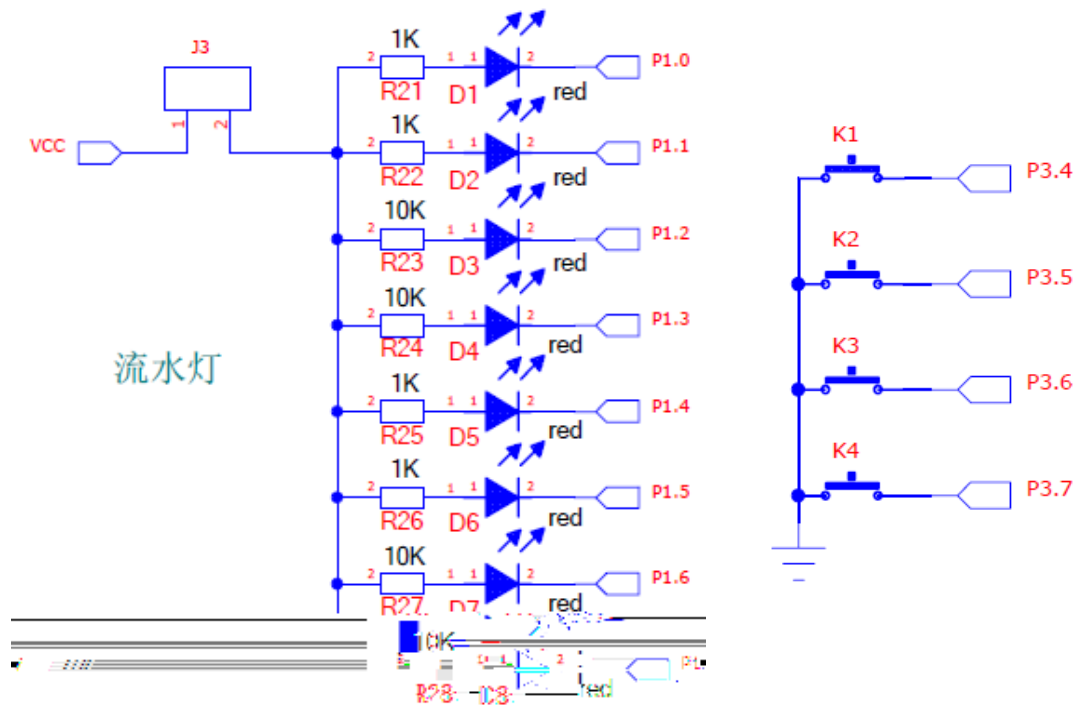



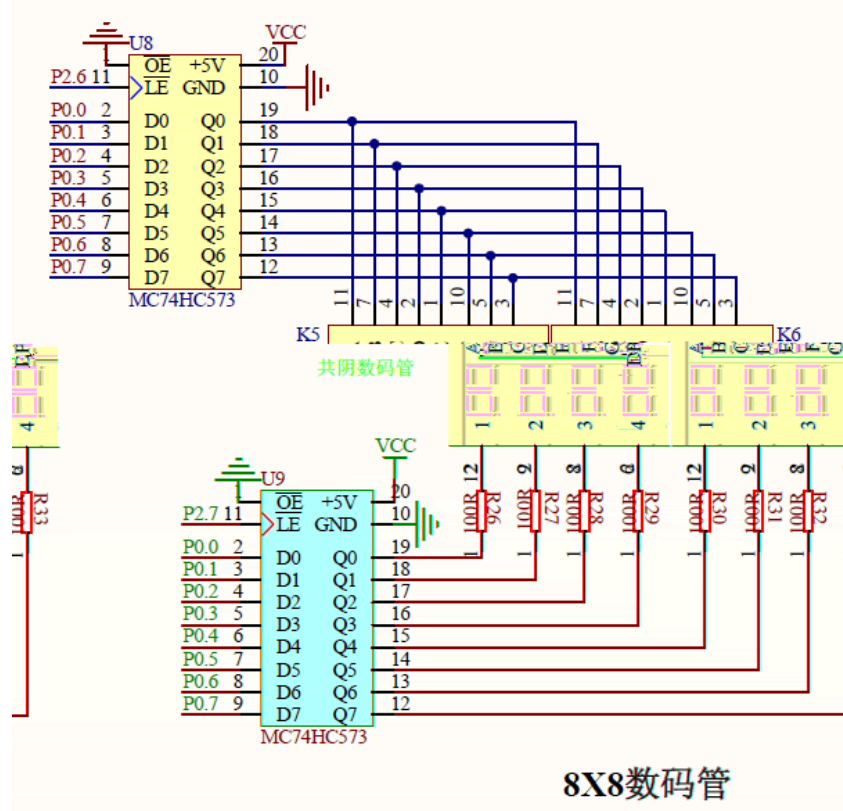
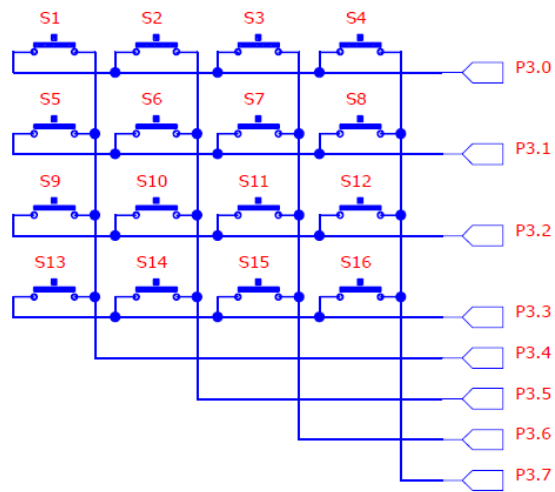

2



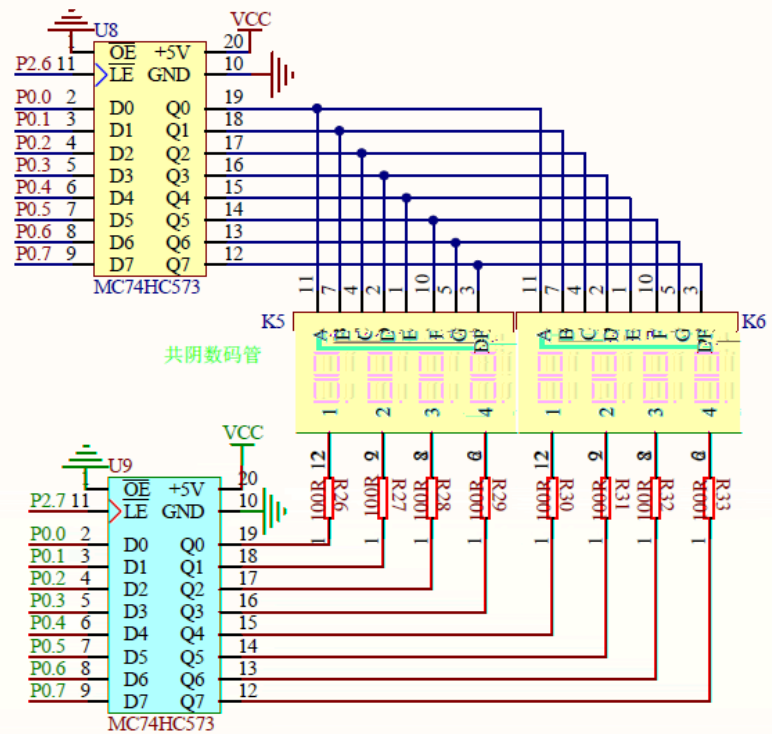
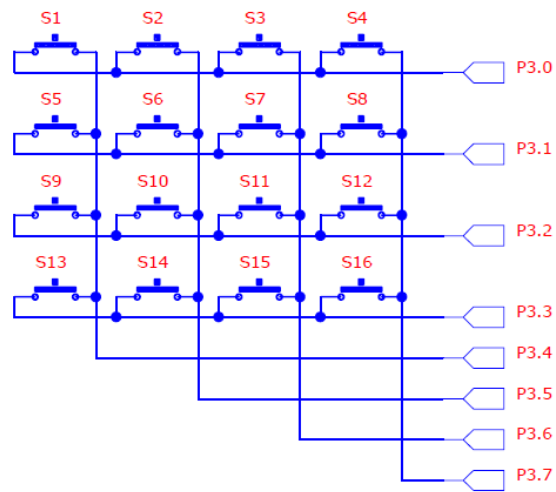

8X8数码管

2

T2-11

1

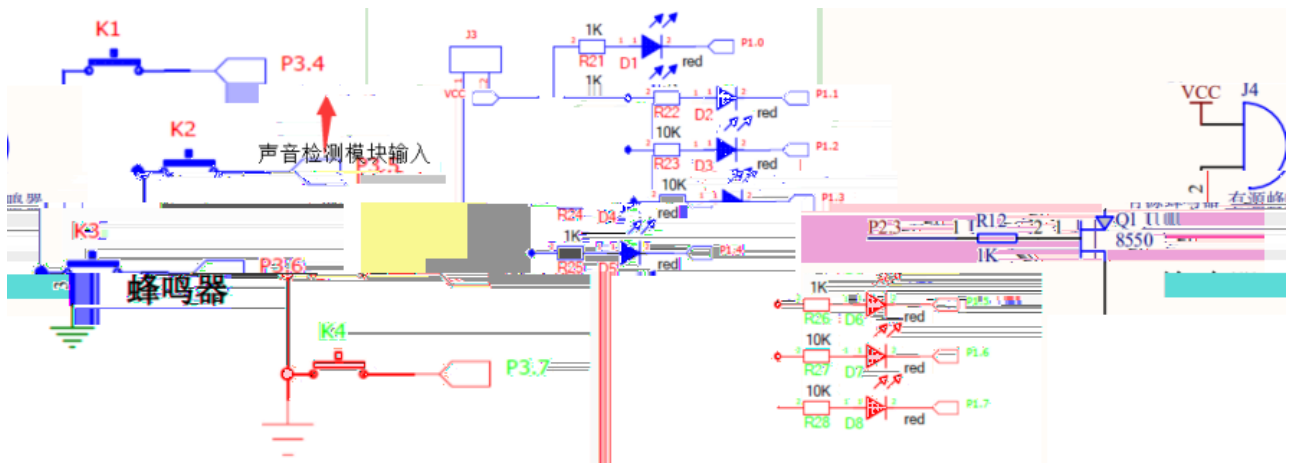

1

2



T2-12

1

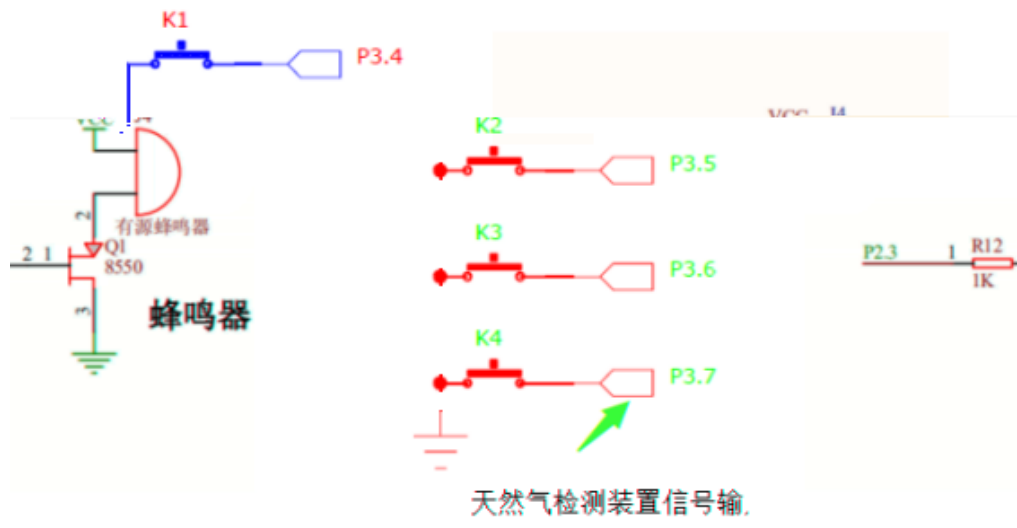

1



T2-13

1

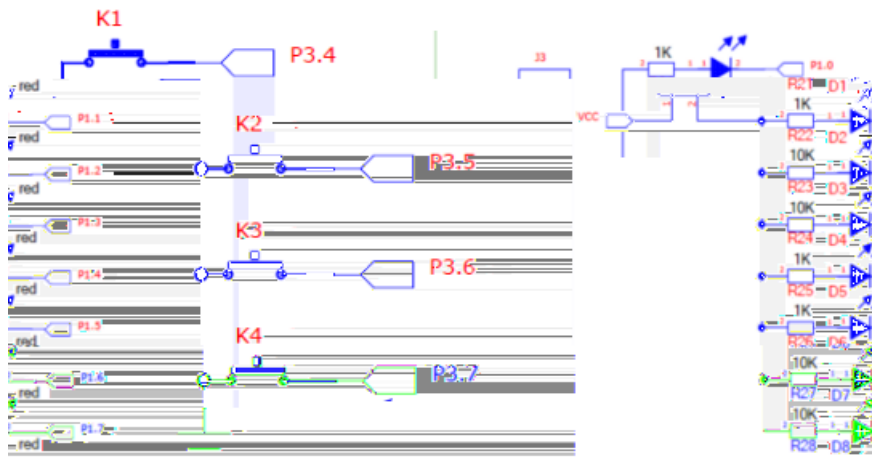

1

2





**T2-14**

1



T2-15

1

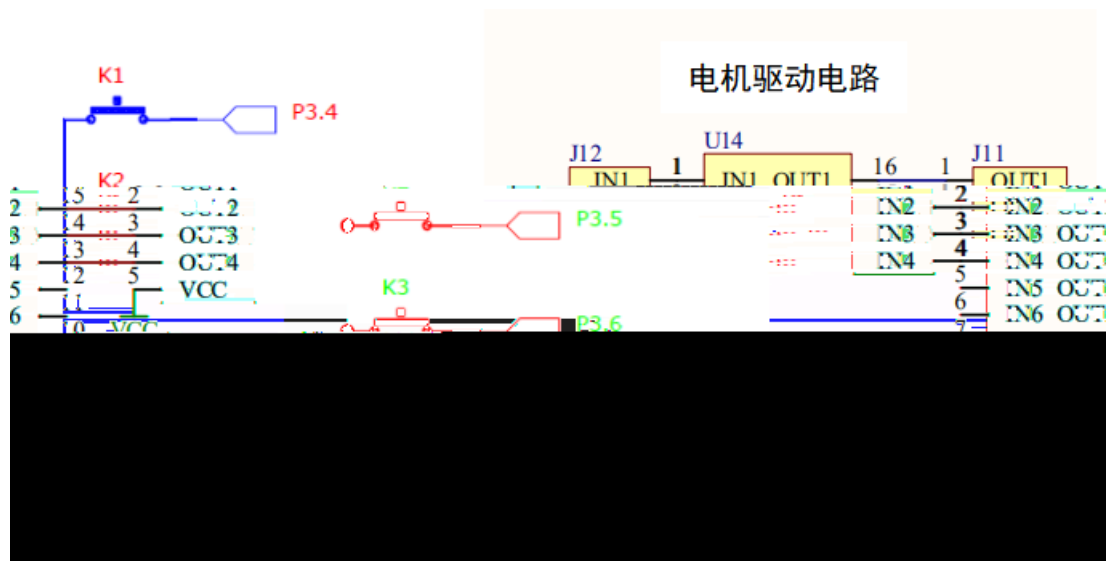

1

2





### H1-1 STM32

1

I/O C

Keil ARM

2

1

/ /  
Keil ARM

MCU

/ /  
2

6S ( )

/

3 120  
4

			5	2

				0



Fire-Debugger DAP



T3-2

1

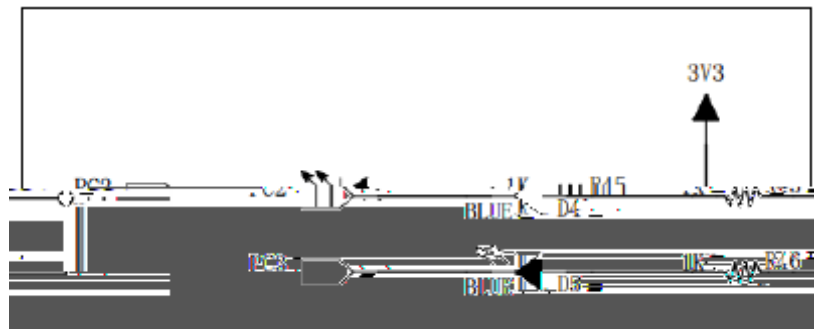

2

Fire-Debugger DAP

T3-3

1

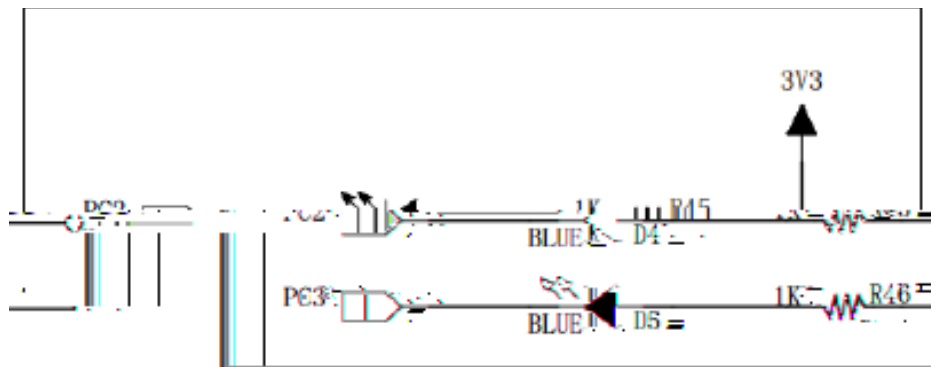
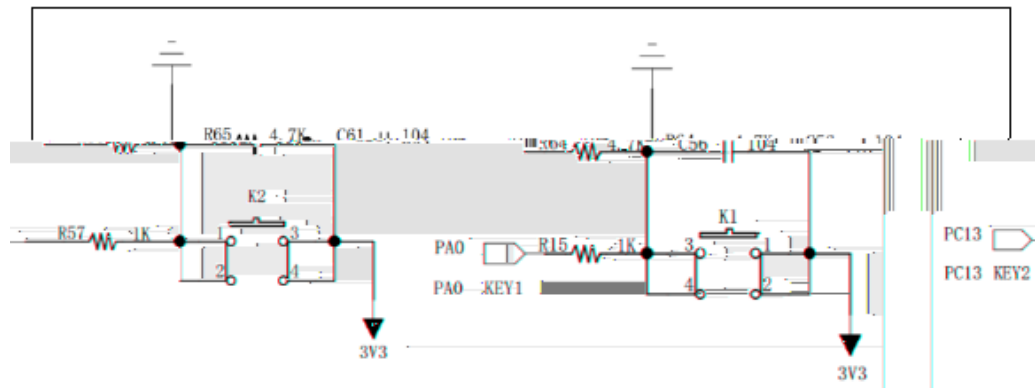

2

Fire-Debugger DAP

T3-4

1

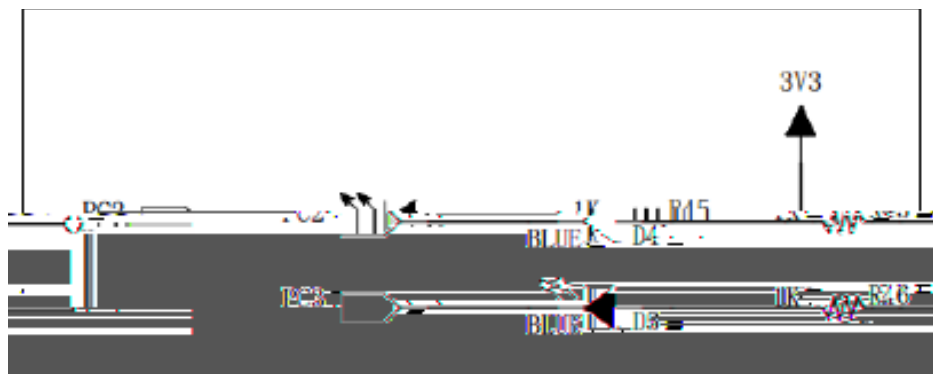
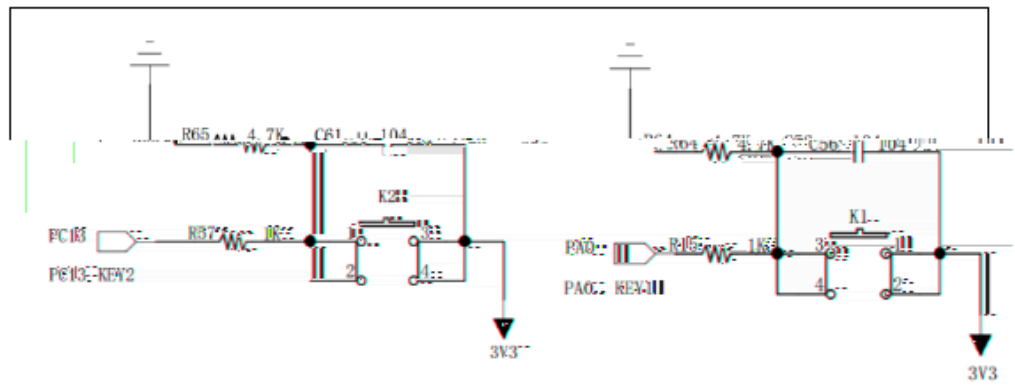

2

Fire-Debugger DAP

1	VBAT	VDD	64
2	PC13/ANT1	VSS	63
3	PC14/OSC32	PB9/TIM4_CH4/SDIO_D5	62
4	PC15/OSC32	PB8/TIM4_CH3/SDIO_D4	61
5	PD0/OSCIN	BOOT0	60
6	PD1/OSCOUT	PB7/I2C1_SDA/TIM4_CH2	59
7	NRST	PB6/I2C1_SCL/TIM4_CH1	58
8	PC0/ADC10	PB5/I2C1_SMBA/SPI3_MOSI/I2S3_SD	57
9	PC1/ADC11	PB4/JNTRST/SPI3_MISO	56
10	PC2/ADC12	PB3/JTDO/SPI3_SCK/I2S3_CK	55
11	PC3/ADC13	PD2/U5_RX/TIM3_ETR/SDIO_CMD	54
12	VSSA	PC12/U5_TX/SDIO_CK	53
13	VDDA	PC11/U4_RX/SDIO_D3	52
14	PA0/WKUP/ADC0/TIM2_CH1_ETR/TIM5_CH1/TIM8_ETR	PC10/U4_TX/SDIO_D2	51
15	PA1/ADC1/TIM2_CH2/TIM5_CH2	PA15/JTDI/SPI3_NSS/I2S3_WS	50
16	PA2/U2_TX/ADC2/TIM2_CH3/TIM5_CH3	PA14/JTCK/SWCLK	49
17	PA3/U2_RX/ADC3/TIM2_CH4/TIM5_CH4	VDD	48
18	VSS	VSS	47
19	VDD	PA13/JTMS/SWDIO	46
20	PA4/SPI1_NSS/ADC5/DAC1	PA12/CAN_TX/USBDP/TIM1_ETR	45
21	PA5/SPI1_SCK/ADC5/DAC2	PA11/CAN_RX/USBDM	44
22	PA6/SPI1_MISO/ADC6/TIM2_CH1/TIM8_BKIN	PA10/U4_C13	43
23	PA7/SPI1_MOSI/ADC7/TIM2_CH2/TIM8_CH1N	PA9/U4_C12	42
24	PC4/ADC14	PB8/U1_TX/TIM1_CH2	41
25	PC5/ADC15	PB7/TIM1_CH1/MCO	40
26	PB0/ADC8/TIM3_CH3/TIM8_CH2N	PC9/TIM8_CH4/SDIO_D1	39
27	PB1/ADC9/TIM3_CH4/TIM8_CH3N	PC8/TIM8_CH3/SDIO_D0	38
28	PB2/BOOT1	PC7/I2S3_MCK/TIM8_CH2/SDIO_D7	37
29	PB10/U3_TX/I2C2_SCL	PC6/I2S2_MCK/TIM8_CH1/SDIO_D6	36
30	PB11/U3_RX/I2C2_SDA	PB15/SPI2_MOSI/I2S2_SD/TIM1_CH3N	35
31	VSS	PB14/SPI2_MISO/TIM1_CH2N	34
32	VDD	PB13/SPI2_SCK/I2S2_CK/TIM1_CH1N	33
		PB12/SPI2_NSS/I2S2_WS/I2C2_SMBAV/TIM1_BKIN	32

Fire-Debugger DAP

T3-6

1

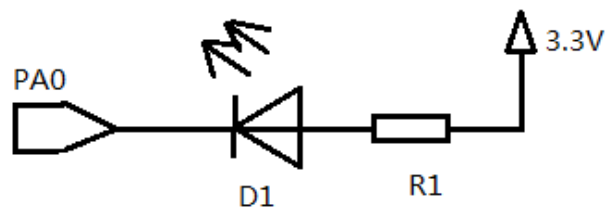

2

Fire-Debugger DAP



T3-7

1

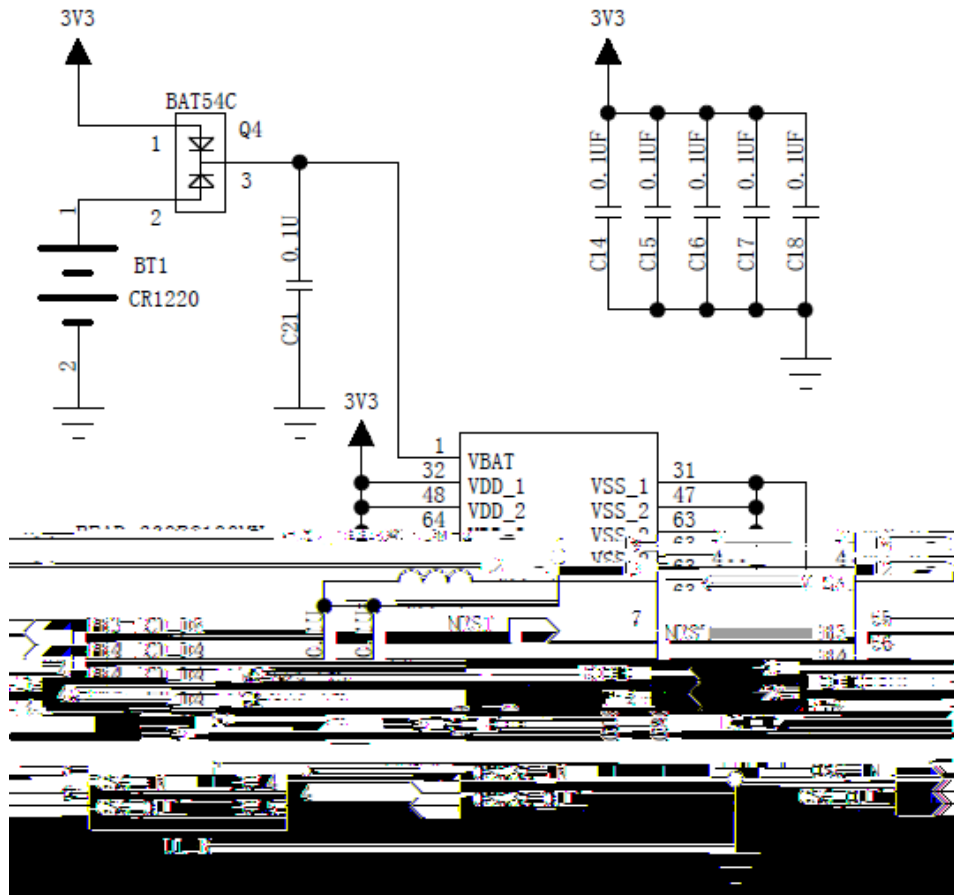

2

Fire-Debugger DAP

T3-8

1

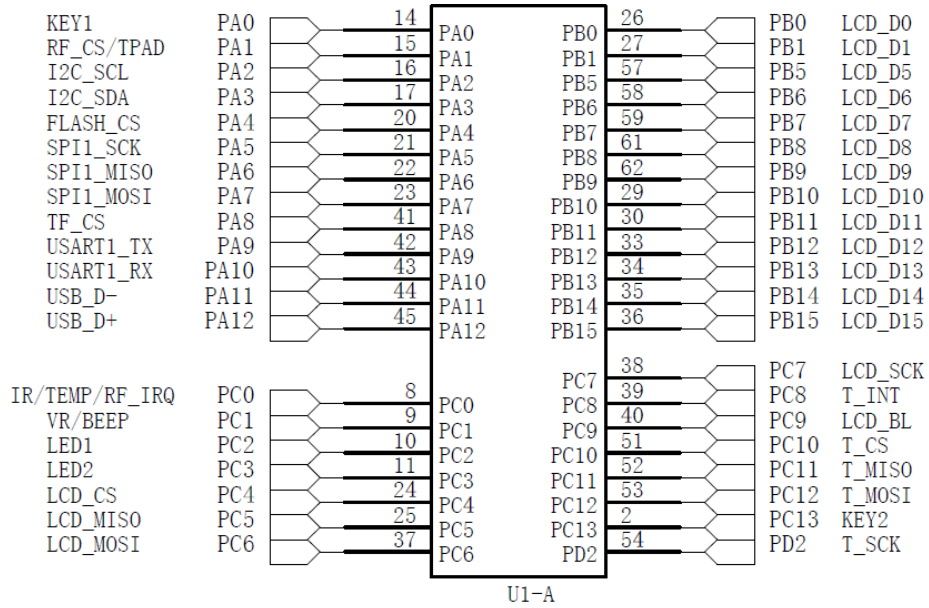

2

Fire-

T3-9

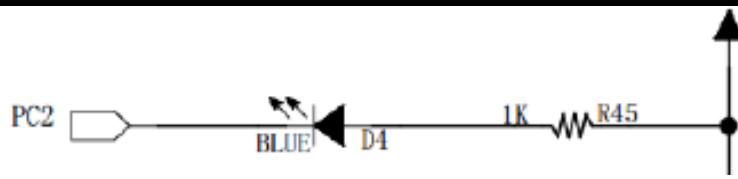
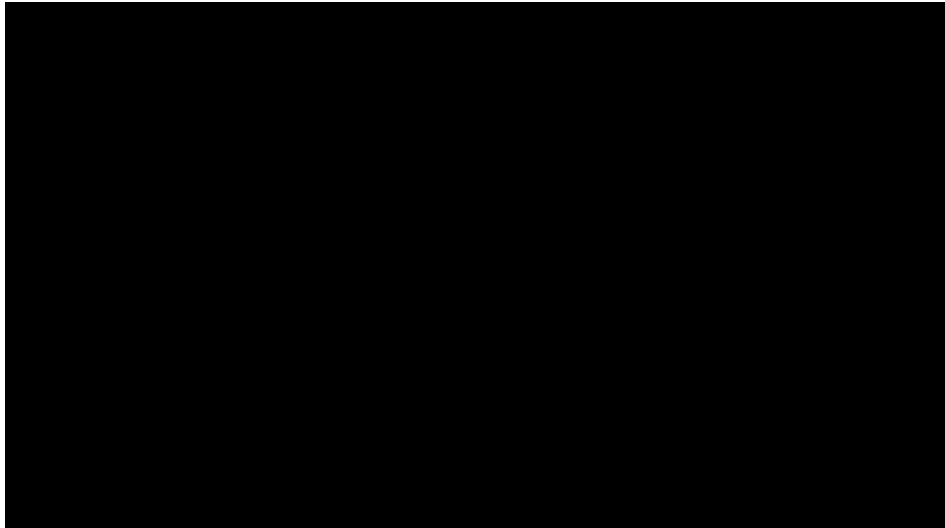

Fire-Debugger DAP

T3-10

1

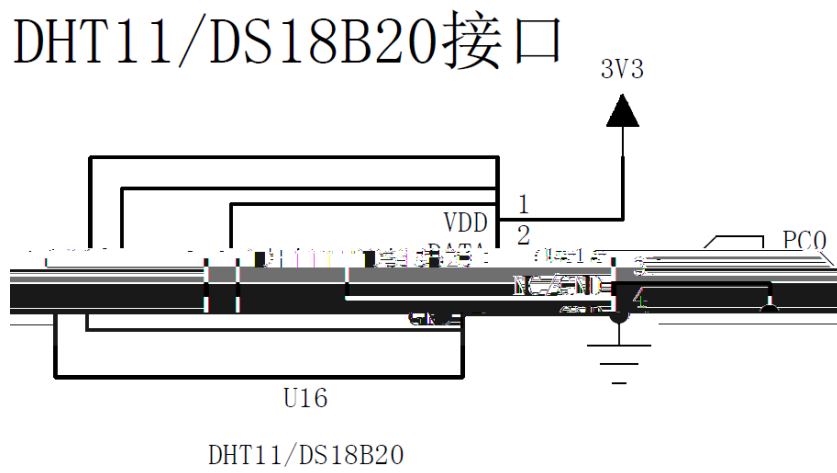

2

Fire-Debugger DAP

**H1-2 Android studio**

1

Android studio

2

1

/ /

AndroidStudio2.2

Android4.0

APP

/ /

2

6S (

)

/



	Android			
--	---------	--	--	--

**T4-1**

**1**

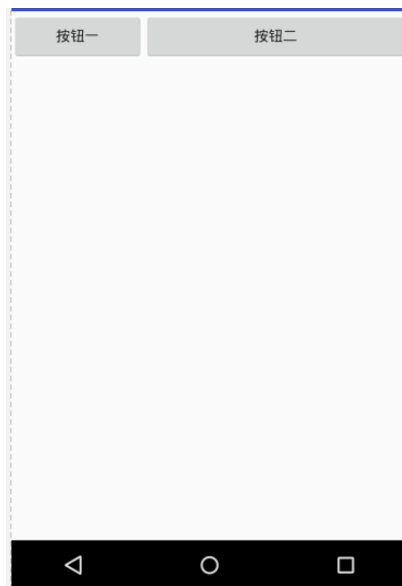

T4-2

1

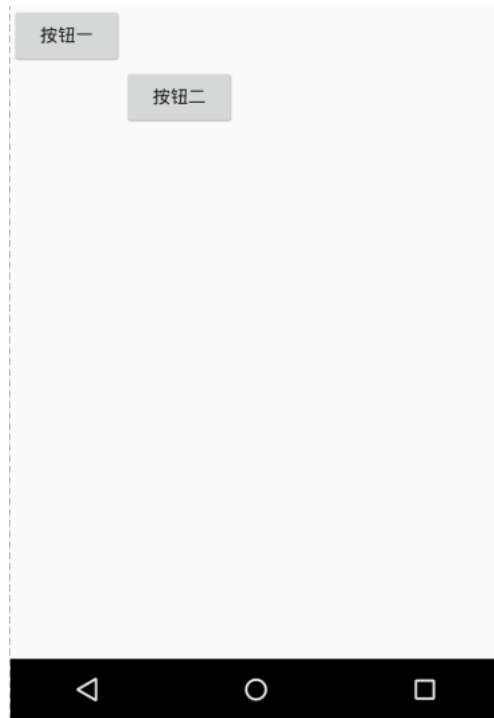

T4-3

1



T4-4

1

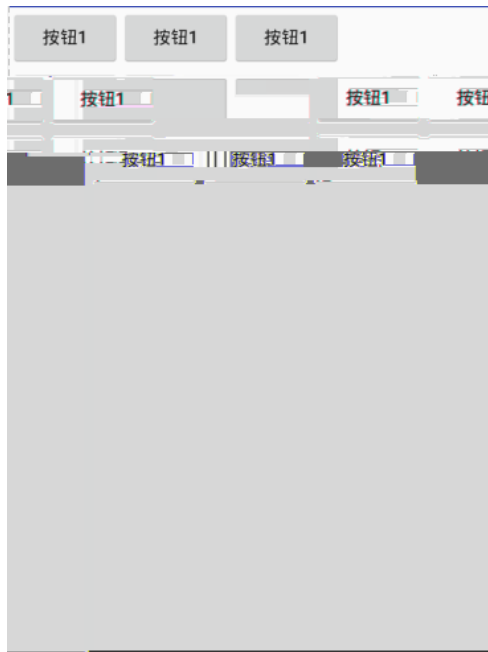

T4-5

1

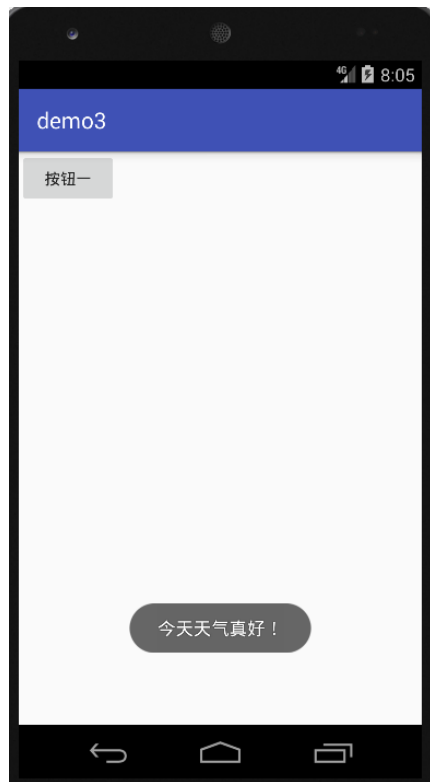

T4-6

1

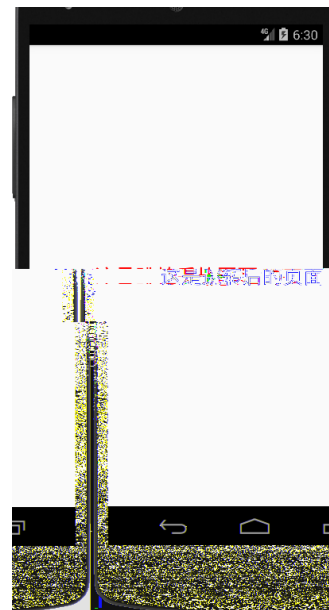





T4-8

1

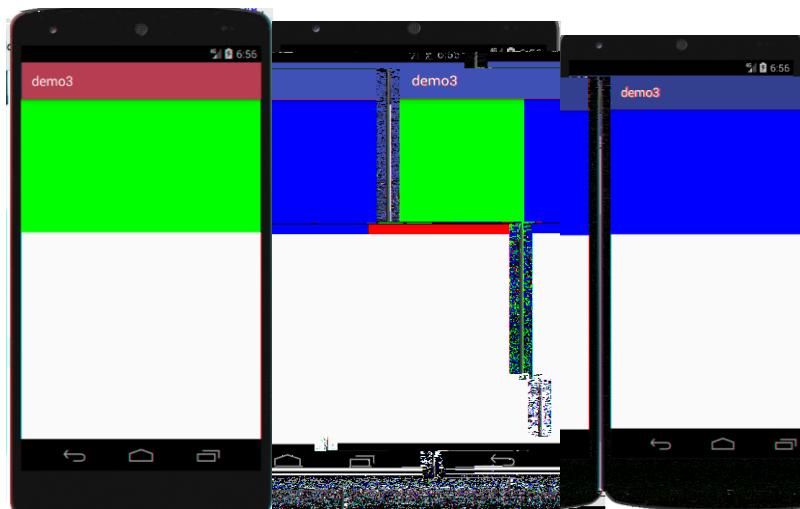

T4-9

1

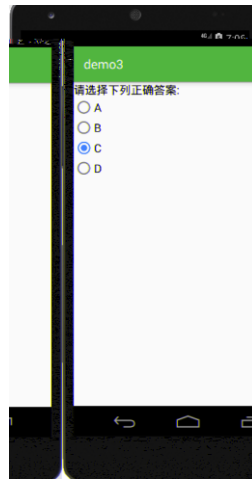
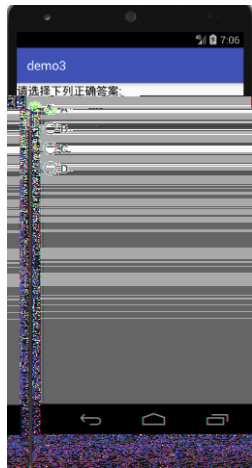

T4-10

1



